

NovaBone® MIS

Delivery System with Tip



Surgical Technique Guide

Product Description

The **NovaBone® MIS Delivery System** is designed for delivering pre-loaded cartridges of **NovaBone Putty**, the next-generation synthetic bone graft. The system includes a metal tip accessory to enhance precision and backfill empty spaces as small as 3.5mm in diameter.

NovaBone Putty is an osteoconductive bioactive device used for grafting osseous defects. It is a pre-mixed composite of bioactive calcium-phospho-silicate particulate and a synthetic, absorbable binder. The bioactive particulate is composed solely of elements that exist naturally in normal bone (Ca, P, Na, Si, O). The absorbable binder is a combination of polyethylene glycol and glycerin. The device requires no mixing or preparation prior to application. The non-hardening putty is supplied ready-to-use, to be applied directly to the intended graft site.

Osteostimulation:

In contrast to bioinert synthetic grafts, **NovaBone** bone graft products belong to the category of bioactive regenerative materials. They not only serve as osteoconductive scaffolds but also interact with the surrounding tissues to provide an osteostimulatory effect. **Osteostimulation**, an active process, is facilitated by the **NovaBone** particles, which act as a bone matrix, encouraging the differentiation of new bone cells at the implant site.

This interaction leads to a controlled resorption rate and accelerated bone regeneration. By leveraging the benefits of osteostimulation, **NovaBone** biomaterials offer a unique solution for promoting faster and more efficient bone healing.

For indications, contraindications, warnings and precautions please review the device IFU.

Table of Contents

Product Description	2
Osteostimulation.....	2
Kit Configurations.....	3
Instructions for Use	4
Delivery System – Assembly and Graft Delivery.....	4-7
Device Specifications and Measurements	8

Surgical Technique Guide

Kit Configurations

The NovaBone® MIS Delivery System is available as a sterile bone grafting kit catered to the minimally invasive surgery field. The kit consists of pre-filled putty cartridges, a delivery dispenser, and an optional metallic conical tip accessory. Refill cartridges and dispenser with tip may also be ordered separately. Both components – cannula and dispenser – are necessary to successfully extrude the putty to the orthopedic surgical site. The following kit configurations are available to order:

Part Number	Description
NB6710	MIS Putty System, 10cc: <ul style="list-style-type: none">• x1 Delivery Dispenser• x2 Pre-filled Cannulas• x1 Conical Tip Accessory
NB6700	MIS Dispenser: <ul style="list-style-type: none">• x1 Delivery Dispenser• x1 Conical Tip Accessory
NB6650	NB Putty Refill Cartridge, 5cc: <ul style="list-style-type: none">• x1 Pre-filled cartridge



Instructions for Use

It is important to read and understand the following instructions prior to clinical use. Improper preparation technique may adversely affect properties and/or performance.

Note: Assembly of components is required. Both the pre-filled cartridge and the delivery dispenser must be present in the operating room (O.R.) to successfully deliver NovaBone® graft material to the surgical site.

NovaBone® MIS Delivery System kit (with and without pre-filled cartridges) is packed in a double, inner and outer, sealed trays and is provided sterile.

NovaBone® Putty Refill Cartridge is packaged within pre-sterilized inner/outer pouches.

Please refer to the Instructions for Use (IFU) for storage and stability instructions.

Delivery System - Assembly and Graft Delivery

Step 1: Prepare the Delivery System

- Non-sterile team member: Open the delivery dispenser tray and aseptically present the inner tray to the sterile team member.



Step 2: Remove the Delivery System

- Sterile team member: Open the inner tray and remove the delivery dispenser with plunger.



Step 3: Prepare the Cartridge

- Unscrew and remove cap from one end of the cartridge.



Step 4: Attach the Cartridge

- Screw the cartridge firmly onto the dispenser and remove the cap on the opposite end.



Step 5 (Optional): Attach the Conical Tip Accessory

- Screw the conical tip accessory firmly onto the attached cartridge. Note: to avoid cross-threading, 1st turn the tip counterclockwise until the threading aligns, then screw clockwise.



Step 6: Dispense Graft Material

- The delivery system is now ready to use. Pull the trigger repeatedly to dispense the graft material to the desired site. For optimal dispensing, a speed of **one (1) squeeze per second** is recommended



Step 7: Replace the Cartridge (if necessary)

- To remove an empty cartridge, lift the black release latch, pull the plunger to its rearmost position, unscrew the empty cartridge and discard. Repeat steps 3-6 when using multiple cartridges during a procedure



Device Specifications and Measurements

Drawing not to scale.

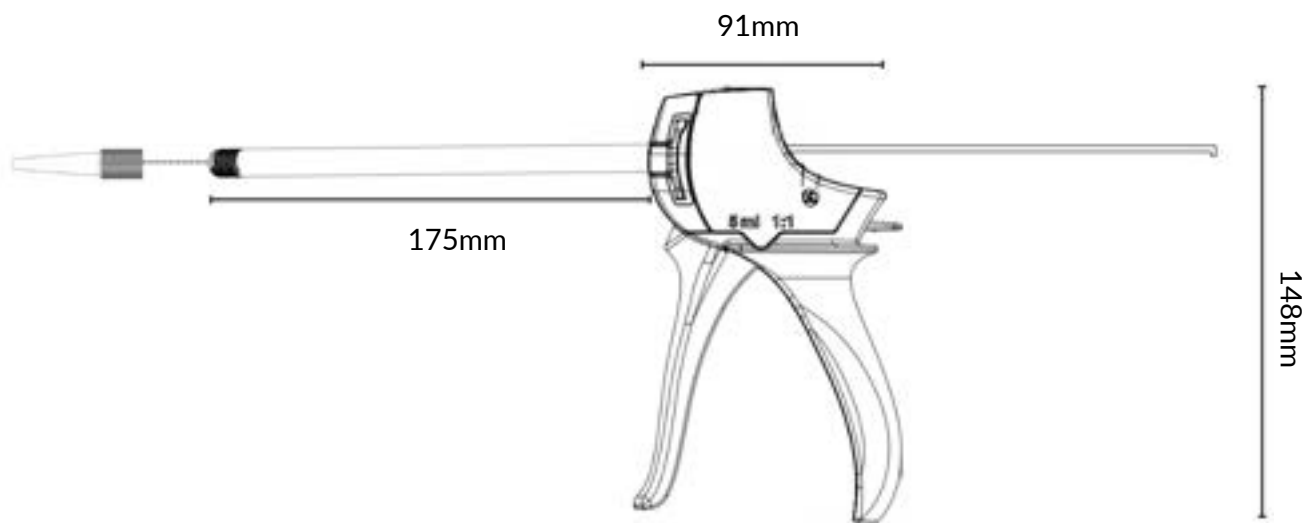

NovaBone® MIS

Delivery System with Tip



Surgical Technique Guide